

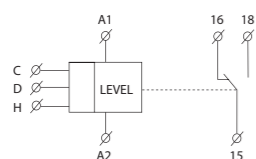

EAN code
HRH-7: 8595188149471

Technical parameters	HRH-7
Function:	2
Supply terminals:	A1 - A2
Supply voltage:	24.. 240 V AC / DC (AC 50 - 60 Hz)
Burden:	max. 2 VA / 1.5 W
Max. dissipated power (Un + terminals):	3 W
Supply voltage tolerance:	-15 %; +10 %
Max. value of overcharge protection:	16 A
Measuring circuit	
Sensitivity (input resistance):	adjustable from 5 kΩ - 100 kΩ
Voltage on electrodes:	max. AC 3.5 V
Current on probes:	AC < 0.1 mA
Time response:	max. 400 ms
Max. capacity of probe cable:	800 nF (sensitivity 5kΩ), 100 nF (sensitivity 100 kΩ)
Time delay (t):	adjustable, 0.5 - 10 sec
Time delay (t1):	1.5 sec
Accuracy	
Setting accuracy (mechanical):	± 5 %
Output	
Number of contacts:	1x changeover / DPDT (AgSnO ₂)
Current rating:	16 A / AC1
- contact NO:	15-18: 6A / AC3
- contact NC:	15-16: 3A / AC3
Switching capacity:	4000 VA / AC1, 384 W / DC
Switching voltage:	250 V AC / 24 V DC
Mechanical life:	3x10 ⁷
Electrical life (AC1):	0.7x10 ⁵
Other information	
Operating temperature:	-20 °C to 55 °C (-4 °F to 131 °F)
Storage temperature:	-30 °C to 70 °C (-22 °F to 158 °F)
Electrical strength:	3.75 kV (supply - sensor)
Operating position:	any
Protection:	IP65
Overvoltage category:	III.
Contamination degree:	2
Cable size (mm ²):	max. 2x 2.5 / with sleeve max. 2x 1.5 (AWG 12)
Dimension:	139 x 139 x 56 mm (5.5 x 5.5 x 2.2")
Weight:	241 g (8.5 oz.)
Related standards:	EN 60255-6, EN 61010-1
Recommended measuring probes:	see pg. 100

Symbol



- Suitable to operate / work in harsh conditions due to the high degree of protection IP65
- Switch monitors the level changes in wells, reservoirs, tanks, tankers etc.
- It is possible to select the following configurations:
 - one-level switch of conductive liquids monitors one level (by connecting H and D)
 - two-level switch of conductive liquids monitors two levels (switches on at one level and switched off at another level)
- Choice of function PUMP-UP or PUMP-DOWN
- Adjustable time delay of output (0.5 - 10 s)
- Adjustable sensitivity using potentiometer (5 - 100 kΩ)
- Measuring frequency 10 Hz prevents liquid polarization and increased oxidation of measuring probes
- Measuring circuits are galvanically separated from the power source of the product and circuits of the relay contact by enhanced insulation according to EN 60664-1 for overvoltage category III.
- Output contact: 1x changeover / DPDT 16 A / 250 V AC1

Device description

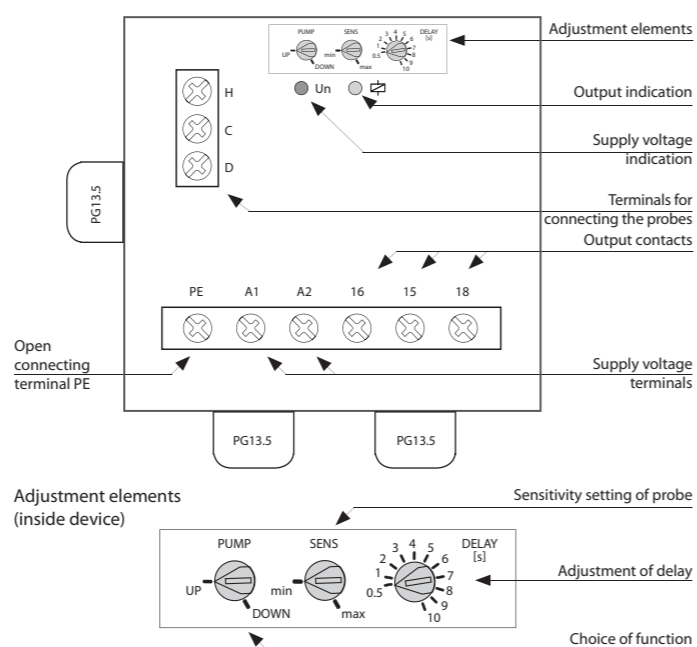

Connection

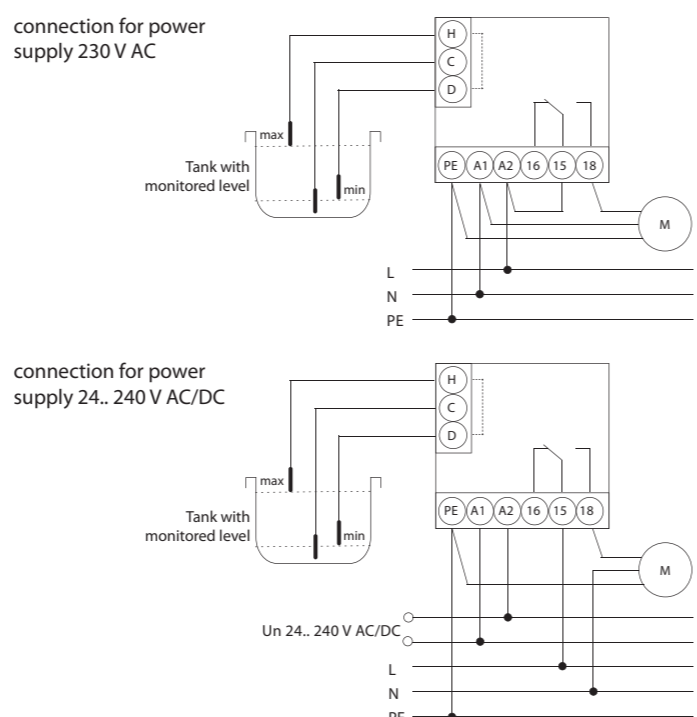

Function

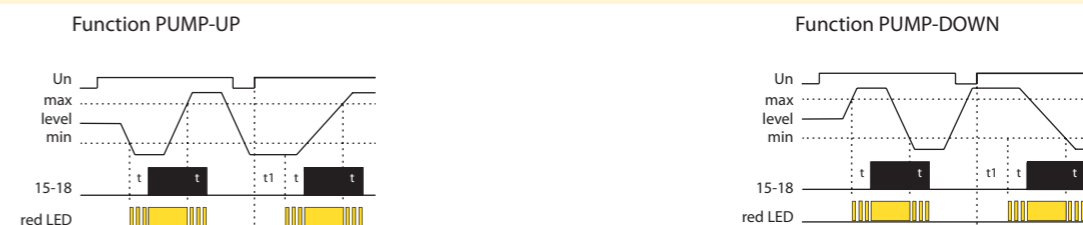

An AC current is used for measuring to prevent polarization and electrolysis of fluid and unwanted oxidation of measuring probes. Three probes are used for measuring: H - upper level, D - lower level and C - common probe. If using a tank made from conductive material, it is possible to use the tank itself as probe C.

If it is necessary to monitor only one level, there are two connection options:

1. Inputs H and D are connected to a single probe - in this case the sensitivity is decreased to half (2.5.. 50 kΩ).
2. Inputs H and C are connected and the probe is connected to input D - in this case, the original sensitivity remains (5..100 kΩ).

It is also possible to connect probe C with a protective conductor of the power system (PE).

Example of connecting the level switch to a 1-phase pump at a well, borehole

wiring for supply 230 V AC (for monitoring two levels)

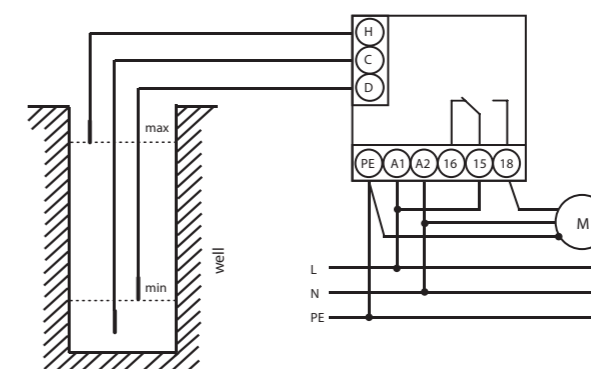

Monitoring TWO LEVELS of the FLUID LEVEL minimum / maximum - DRAINING function - (PUMP DOWN)

Description of draining function:

This function is used in a well or borehole where the difference between the upper and lower probes determines how much water the pump can pump out and protect against running dry.

After detecting the maximum level, the set reaction delay begins running. After this period, the output contact immediately switches on the pump until the minimum level is reached, when the set delay begins running once again. The pump then switches off.

Monitoring TWO LEVELS minimum / maximum - REPLENISHING function - (PUMP UP)

Description of replenishing function:

This function is used when you need to regularly pump in water to a well or borehole, which is leaking.

After detecting the minimum level, the set reaction delay begins running. After this period, the output contact immediately switches on the pump for the period until it reaches the maximum level, where the set delay begins running once again. The pump then switches off.

Example of connecting the level switch to a 3-phase pump at the well, borehole

wiring for supply 230 V AC (for monitoring two levels)

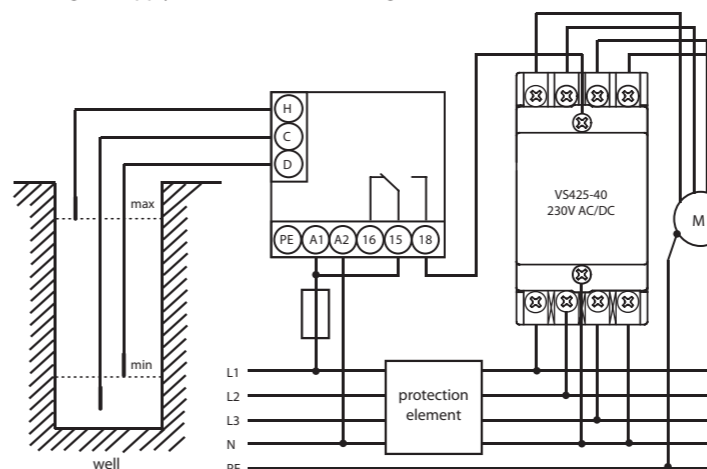

Monitoring TWO LEVELS minimum / maximum - DRAINING function - (PUMP DOWN)

Description of draining function:

The function is used to protect against overflows and flooding of areas. After detecting the maximum level, the set reaction delay begins running. After this period, the output contact immediately switches on the 3-phase pump until the minimum level is reached, when the set delay begins running once again. The pump then switches off.