



TF428WNM/U

Communicating Fan Coil Thermostat

SPECIFICATION DATA



Specifications

Physical Layer	EIA485
Protocol	Modbus RTU
Baud rate	4800/9600(Default)/19200
Parity	None
Error checking mechanism	CRC
Rated voltage & Frequency	220/230VAC, 50/60Hz
Power consumption	<2W
Control	PI, On/off output
Accuracy	±1°C at 21°C
Auto cycle times	100,000 times
Manual cycle times	10,000 times
Protection class	IP20
Setpoint range	10 ~ 32°C
Display range	0 ~ 37°C
Ambient operating limits	0~ 49°C
Ambient storage limits	-30 ~ 60°C
Humidity limits	5~90% RH, non-condensing
Action Type:	1
Pollution Degree	2
Protection against electric shock class	Class II
Electronic control software class	Class A
Rated impulse voltage:	2500V
Maximum temperature	155°C
For relay wiring	
Wire sectional area	1.0~1.5mm ²
(Recommendation)	
Applied altitude up to	2000m above sea level
Rating capacity	
Working current for the whole product :	4(3)A
4A:	When the load of the thermostat is resistance
3A:	When the load of the thermostat is inductance
For Fan load	3(2)A
3A:	when the load is resistance;
2A:	When the load is inductance
For Valve load	2(1)A
2A:	when the load is resistance;
1A:	when the load is inductance
The valve need have	overtravel-limit organ to turn off the load.

General

The TF428WNM/U communicating thermostat is designed for 3-speed fan and valve control in fan coil system, including:

- 2-pipe cooling only/heating only/manual changeover
- 4-pipe cooling/heating manual/automatic changeover
- Ventilation mode
- Manual or automatic 3-speed fan control
- Water valve on/off control

The TF428WNM/U is available in Modbus RTU protocol and can be easily integrated into building automation system.

Features

- **RS485 interface in Modbus RTU slave mode**
- **Memorized time off**
- **Cycle Per Hour (CPH)**
- **Random startup**
- **LCD display with simple user interface**
- **Room temperature or setpoint temperature display selectable**
- **Manual or automatic fan speed selectable**
- **Temperature units in either °C or °F**
- **User setting can be stored when power loss**
- **Freeze protection function available**
- **Keypad lock options**



Model Selection

Model Number	Backlight	Application	Power Supply	Ventilation Mode	Package
TF428WNM/U	White	2-pipe/4-pipe FCU application	220/230Vac; 50/60Hz	Y	Unit Package

Product Design

Thermostat appearance



Dimensions (mm)

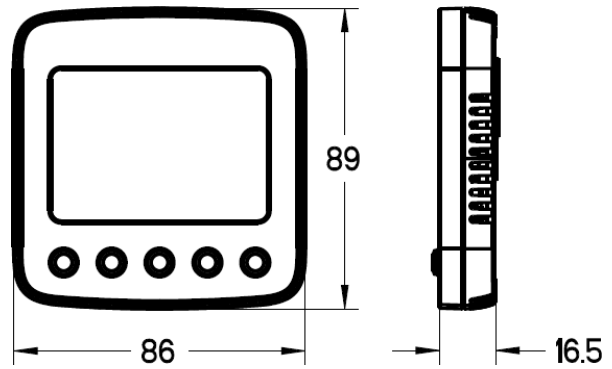

LCD display

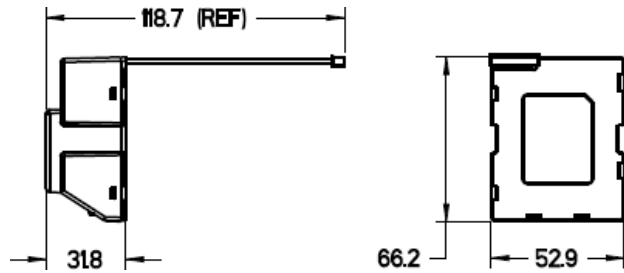
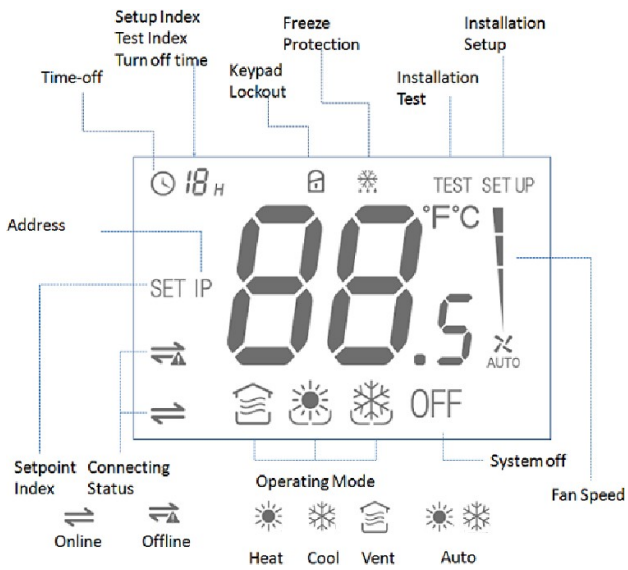

Function

Valve Control

Thermostat measures the room temperature via integrated sensor and maintains the setpoint by delivering on/off valve control command output.

The fan setting can be selected as manual or automatic 3-speed operation. When in “manual” mode, the fan is switched to the selected speed via control output FH (high), FM (Medium) , FL (Low).

When in “auto” mode, fan speed depends on the difference between room temperature and setpoint. When room temperature reaches the setpoint, the valve will be closed, and the fan will be closed in the meanwhile.

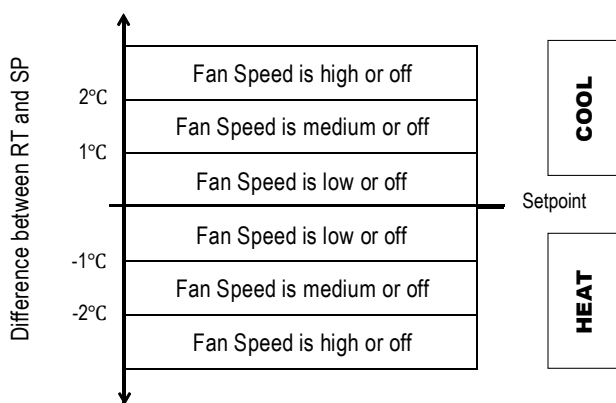

Fig. 1. Fan Speed Ramping Control Algorithm

Memorized Time Off

The time off feature will automatically turn off the thermostat after a selectable amount of time. To change the time setting, press and hold the power button for more than 3 seconds and press “up” and “down” button to change the value when the thermostat is working .

NOTE: The setting range is from 0 to 12 hours. The step is 1 hour and the default value is 0.



Backlight

To turn on the backlight, press any key. The backlight will timeout 8 seconds after the last key is pressed. When in ISU or Installation test mode, the backlight will timeout 60 seconds after the last key is pressed.

Keypad Lockout

Keypad lockout can be set in ISU or over Modbus. The default status is “all keys available”. Keypad lock function can be selected as “mode button locked out”, “Fan and mode buttons locked out”, “all buttons (except power button) locked out” and “all buttons locked out”.

Temperature Display

The displayed temperature can be set to room temperature or setpoint. The setting can be changed during ISU (Installation Set Up) process.

Cycle Per Hour (CPH)

CPH function enables the thermostat to open the valve several times per hour as the room temperature approaches to the setpoint.

The value can be changed in the ISU, the default values are 4 for heating and 3 for cooling.

Operating Mode

Comfort Mode

In comfort mode, the setpoint and fan speed can be changed by pressing corresponding buttons. Comfort mode including 2-pipe cooling only/heating only/manual changeover and 4-pipe manual /auto changeover applications.



Ventilation Mode

Press "mode" button to enter "ventilation" mode. In "ventilation" mode, no output for valve while the fan will operate at selected fan speed.



Freeze Protection Mode

Freeze protection can be selected as disabled or enabled (default) in the ISU or over Modbus. In freeze protection mode when thermostat is off and the temperature is below 6°C, the thermostat will activate heating mode until the temperature rises to 8°C.

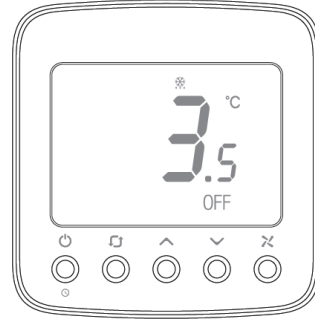

Installation and Wiring

TF428WNM/U can be installed in standard 86 size junction box directly.

-  The screws must be locked tightly to avoid wire break off from the terminals.
- The temperature of mounting box and wall should be in the operating temperature range.

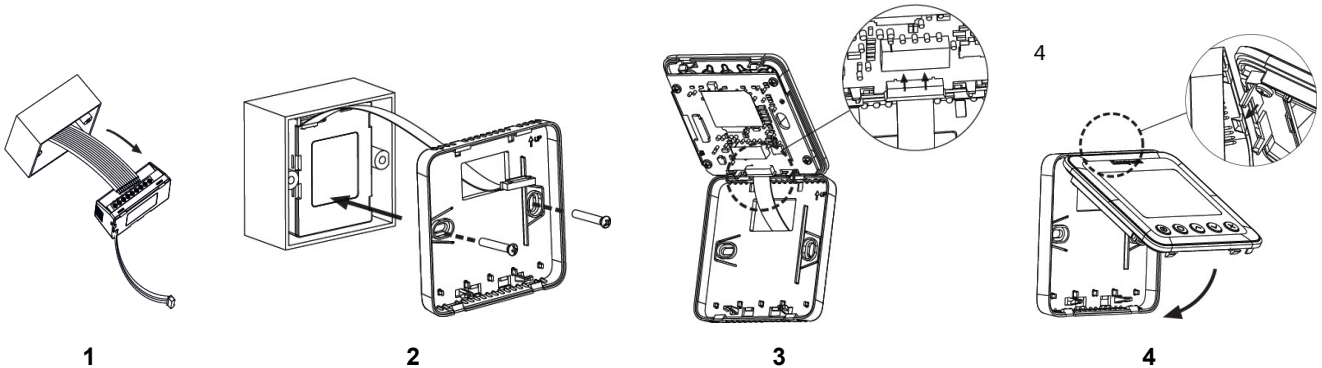

Wiring Diagram

2- pipe application

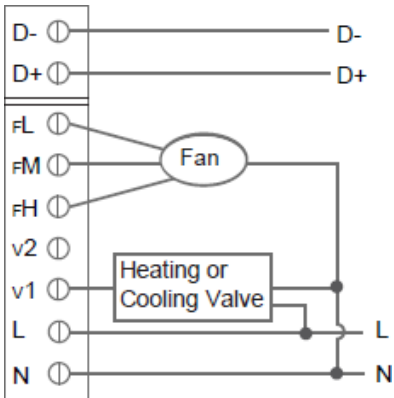

Fig. 2. Honeywell Home VC4013/VN4013/VS4016 Wiring

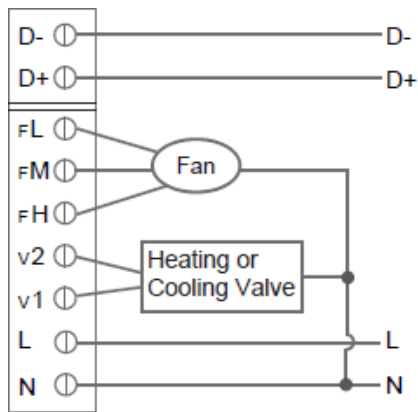

Fig. 3. Honeywell Home VC6013/VN6013 Wiring

4-pipe application

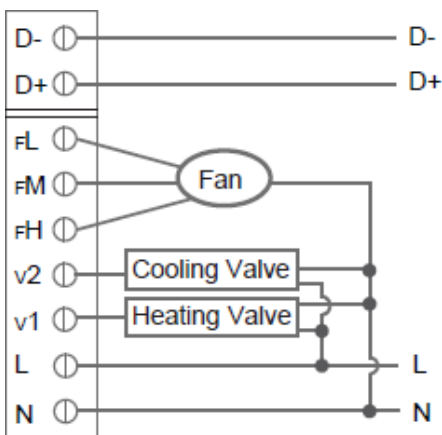

Fig. 4. Honeywell Home VC4013/VN4013/VS4016 Wiring

Note: when in 4-pipe application, the thermostat can not be connected with Honeywell Home VC6013/VN6013 series motorized valve

Terminal Designations

Terminal	Description
D-	Modbus 485-
D+	Modbus 485+
FL	Low speed fan
FM	Medium speed fan
FH	High speed fan
V2	2-pipe application_VC6013: valve close 4-pipe application_VC4013: cooling valve open
V1	2-pipe application_VC4013/VC6013: valve open 4-pipe application_VC4013: heating valve open
L	Live wire
N	Neutral wire

ISU (Installation Setup)

Press and hold the “mode” and “up” buttons together for more than 3 seconds to enter or exit ISU. Change the ISU code by pressing the “mode” button and then change the option setting by pressing the “up” and “down” button refer to the following introduction.

ISU Code	Description	Options
0	Modbus Address	1~64 1(Default)
1	System Type	0 Heating only
		1 Cooling only
		2 Two pipes heating/cooling manual (Default)
		4 Fur pipes manual
		5 Four pipes auto
2	Temp. Scale	0 °F
		1 °C (Default)
3	Fan Control Type	0 Auto only
		1 Manual only (3 speed: Low→Med→High→Low)
		2 Users can choose auto or manual (Default)
4	Switching Differential for 4 pipe Auto Changeover With Single Setpoint	1°C (2°F)
		1.5°C (3°F)(Default)
		2°C (4°F)
		3°C (5°F)
5	CPH (Heat)	1~12 4(Default)
6	CPH (Cool)	1~6 3(Default)
7	Display Temp. Adjustment	-2~2°C, 0.5°C. Default 0°C (-4~4°F, 1°F. Default 0°F)
8	Temp. Display	0 Room temp. (Default)
		1 Setpoint
9	Heating Range Stops	10~32°C. Default 32°C (50~90°F. Default 90°F)
10	Cooling Range stops	10~32°C Default 10°C (50~90°F. Default 50°F)

ISU Code	Description	Options
11	Keypad Lockout	0 All keys are available (Default)
		1 Mode button locked out
		2 Fan and mode buttons locked out
		3 All buttons locked out except power button
12	Freeze Protection	4 All buttons are locked
		0 Disabled
13	Power Recovery Status	1 Enabled (Default)
		0 OFF
14	Modbus Baud Rate	1 Previous status (Default)
		0 9600(Default)
		1 4800
		2 19200

Modbus Address Table

When the thermostat is integrated into building automation system. Please make configuration refer below list.

Address Registers	Parameters	Properties and Value	Properties
01	Power Switch	0-Off;1-On	R/W
02	Room Temperature	Room temperature value	R
03	Temp. Scale	0-°F; 1-°C	R/W
04	Setpoint	Set temperature value	R/W
05	Fan Speed	0-Auto;1-Low speed;2-Med speed;3-High speed	R/W
06	System Mode	0-Ventilation;1-Heating;2-Cooling;3-Auto	R/W
07	V1 Valve Status	0-Closed;1-Open	R
08	V2 Valve Status	0-Closed;1-Open	R
09	Error Code	0-None; 1-Sensor; 2-EEprom; 3-Sensor+EEprom	R
10	Fan Status	0-Off 1-Low 2-Med 3-High	R
11	Modbus Address	1~64 1(Default)	R/W
12	System Type	0-Heating only;1-Cooling only; 2-Two pipes heating/cooling manual (Default) 4-Four pipes manual;5-Four pipes auto	R/W
13	Fan Control Type	0-Auto; 1-Manual; 2-Auto+Manual (Default)	R/W
14	Switching Differential For 4 pipe Auto Changeover With Single Setpoint	2-1°C(2°F); 3-1.5°C(3°F); 4-2°C(4°F); 5-3°C(5°F);	R/W
15	CPH (Heat)	1-12 4 (Default)	R/W
16	CPH (Cool)	1-6 3 (Default)	R/W
17	Display Temp. Adjustment	0~8(-2~2°C) step1(0.5°C) 4 (Default) 0~8(-4~4°F) step1(1°F) 4 (Default)	R/W
18	Temp. Display	0- Room temp. (Default) ;1-Setpoint	R/W
19	Heating Range Stops	100~320 (10~32°C) step5(0.5°C) 320 (Default) 500~900 (50~90°F) step10(1°F) 900 (Default)	R/W
20	Cooling Range Stops	100~320 (10~32°C) step5(0.5°C) 100 (Default) 500~900 (50~90°F) step10(1°F) 500 (Default)	R/W

Address Registers	Parameters	Properties and Value	Properties
21	Keypad Lockout	0- All keys are available (Default); 1– Mode button locked out;2- Fan and mode buttons locked out;3- All buttons locked out except power button;4- All buttons locked out	R/W
22	Freeze Protection	0- Disabled; 1- Enabled (Default)	R/W
23	Power Recovery Status	0- OFF; 1-Previous Status (Default)	R/W
24	Modbus Baud Rate	0-9600 (Default) ;1-4800;2-19200	R/W
25	Time Off Time	0~12 Step 1 Unit :h	R/W
26	Remain Time To Turn Off	Remain time to turn off	R

Note: 1 The parameters are registers, 16 bit integer. Modbus Function is 0x01(read),0x06(write single),0x10(write multiple).

2 Max. 31 devices in one network.



Ademco 1 GmbH
 Hardhofweg 40
 74821 Mosbach
 Phone: +49 1801 466 388
 info.de@resideo.com
 homecomfort.resideo.com

@2020 Resideo Technologies, Inc.
 All rights reserved. The Honeywell Home
 trademark is used under license from
 Honeywell International Inc. This product
 is manufactured by Resideo Technologies,
 Inc and its affiliates.

